

Congratulations on your purchase of a DiUV Self-cleaning disinfection unit from Premier Tech Aqua (PTA). With the DiUV Self-cleaning disinfection unit, you have wisely chosen to protect your health and your environment. This manual contains information on operation, operating guidelines, maintenance as well as warranties for the DiUV Self-cleaning disinfection unit.

The DiUV Self-cleaning disinfection unit coupled with an Ecoflo® Biofilter is a tertiary treatment system with disinfection certified Class V of Standard NQ 3680-910. It includes a septic tank, an effluent filter, an Ecoflo® Biofilter and a DiUV Self-cleaning disinfection unit. All information relative to the operation, operating guidelines and maintenance of the septic tank, effluent filter and Ecoflo® Biofilter can be found in the Ecoflo® Biofilter Owner's manual. For additional information, please contact our Customer Service Department at 1 800 632-6356 or visit our website at PREMIERTECHAQUA.COM.



Table of contents

1. Operating principles	2
2. Operating guidelines	3
2.1. Type of wastewater that can be treated	3
2.2. Recommendations	4
2.3. What you need to know	4
3. DiUV Self-cleaning attributes.....	5
3.1. Visual and audio alarm systems	5
4. Maintenance	7
4.1. Septic tank	7
4.2. Advanced secondary treatment system	7
4.3. DiUV Self-cleaning disinfection unit	7
5. Sampling.....	7
6. What to do in case of.....	8
6.1. An activated alarm	8
6.2. A prolonged power failure.....	8
6.3. Flooding	8
6.4. Odours	8
6.5. Backflow	8
6.6. Winter closing of residences.....	8
DiUV Self-cleaning disinfection unit certificate of warranty.....	8
Notice of new property owner.....	11

1. Operating principles

The purpose of the DiUV Self-cleaning disinfection unit is to reduce the concentration of fecal coliforms below 200 UFC/100 mL¹. The operating principle of the DiUV Self-cleaning disinfection unit is to expose microorganisms to ultraviolet rays. The dose depends on the time of exposure and the intensity of the rays. This flow entering the unit ensures maximum exposure time and the quartz sleeve is kept clean to optimise the intensity of the rays.

Main components & functions

A- Tank and lid

- Connects the disinfection chamber with the rest of the treatment system;
- Resists soil movements;
- Ensures the system is watertight and protects the internal components;
- Limits access with bolts.

B- Water inlet ball valve

- Isolates UV unit during maintenance.

C- Anti-siphon

- Allows the overflow pipe to empty after a pumping event.

D- UV Unit

- Includes 2 UV lamps and the quartz sleeve;
- Exposes the effluent to UV rays;
- Equipped with a self-cleaning system.

E- Sliding rail system

- Attaches the UV unit to the tank;
- Allows easy removal of the UV unit for maintenance.

F- Sampling point

- Is used to collect samples of treated effluent;
- Allows filling of UV unit upon installation.

G- Junction box

- Protects electrical connections.

H- Alarm box (installed inside the dwelling) and alarm float

- An alarm is used to detect and inform about abnormal presence of water in the tank;
- An alarm is used to detect and inform when the UV unit is not functioning properly.

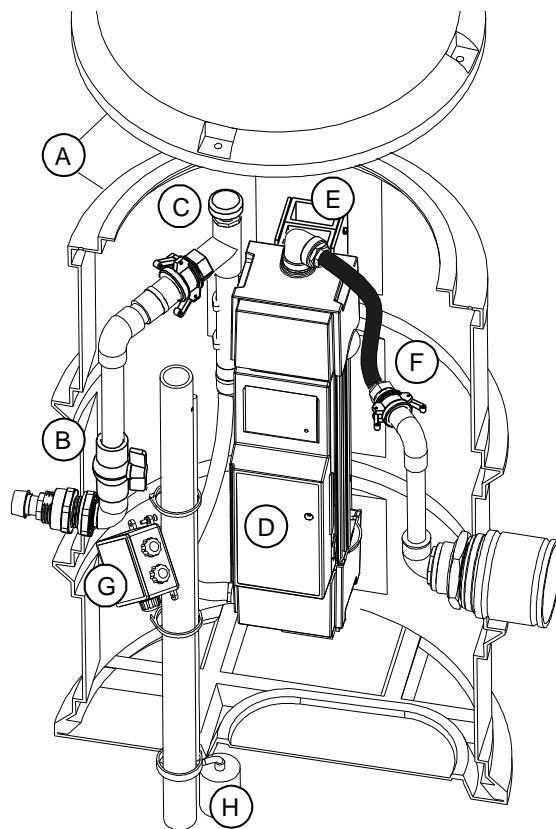

¹ The maximum concentration for tertiary treatment systems with UV disinfection must be divided by a factor of 10 to take into account the reactivation of fecal coliforms after disinfection.

The table below indicates the capacity of the **DiUV Self-cleaning disinfection unit**.

Number of bedrooms	Total daily flow (litres)	Number of DiUV Self-cleaning disinfection unit required
1	540	1
2	1080	1
3	1260	1
4	1440	1
5	1800	1
6	2160	1
Other buildings ruled by <i>Q-2, r.22</i>	3240	1

2. Operating guidelines

2.1. Type of wastewater that can be treated

Using a secondary or advanced secondary treatment system

Domestic wastewater (for example: wastewater from onsite installation)

Using the DiUV Self-cleaning disinfection unit

Domestic wastewater coming from an **advanced secondary treatment system** certified under Standard NQ 3680-910 for an advanced secondary level (Class III). The DiUV Self-cleaning disinfection unit is compatible with most advanced secondary treatment systems. To be installed in Quebec at a flow rate below 3 240 L/d the treatment chain consisting of an advanced secondary treatment and the DiUV Self-cleaning disinfection unit system must be certified under Standard NQ 3680-910.

Water supply source quality analysis

No drinking water test required – unit less sensitive to water hardness than conventional UV lamps.

- Hardness < 500 mg/L

Drinking water filtration system

If your home is equipped with a drinking water filtration system (for example, water softener, green sand filter, etc.), **the backwash from this system must never be sent to the wastewater system since this could damage the DiUV Self-cleaning disinfection unit.**

2.2. Recommendations

IT IS RECOMMENDED THAT YOU NOT flush any of the following down the toilet:

- Water softener backwash;
- Oil and grease (motor oil, cooking oil, etc.);
- Wax and resins;
- Paints and solvents;
- Petroleum products;
- Any kind of pesticide;
- Any kind of septic tank additive;
- Toxic substances;
- Anything not easily biodegradable (for example: coffee beans, cigarette butts, sanitary napkins, tampons, condoms, cotton swabs, etc.)



Respect the following instructions:

- **NEVER** open the access lid or go inside the DiUV Self-cleaning disinfection unit unless authorized;
- **NEVER** cover or bury the access lid(s) of the components of your septic system. Once the landscaping has been done, the lid of the tank must be 50 mm (2") above the surface of the finished lot;
- **NEVER** connect a drainage pipe, roof gutter, sump/drainage pump or air condition drain to your septic system;
- **NEVER** operate a vehicle or place any item weighing more than 225 kg (500 lb) within 3 m (10') of the lid;
- **DO NOT** let anything that might cause an overload collect on top of your septic system (for example, blown snow). The overload could damage your system;
- **NEVER** use automatic toilet cleaners;
- **NEVER** add extensions on the access of the DiUV Self-cleaning disinfection unit;

By respecting these instructions, you contribute to the proper operation of your septic system and increase the chances of lengthening its life span.

WARNING! DO NOT HANDLE

The handling of this DiUV Self-Cleaning ultraviolet disinfection treatment unit from Premier Tech is dangerous for your health and carries a serious risk of eye injury.

Only a duly authorized representative of Premier Tech can handle or maintain this equipment.

For more information, please contact Premier Tech at 1 800 632-6356.

2.3. What you need to know

Owner's responsibility

The owner must respect all existing laws and regulations regarding the quality of the effluent from the system and its discharge into the environment.

Keep heavy weights off your system

Never operate a vehicle or place objects weighing more than 225 kg (500 lb) within 3 m (10') of the lid. If you plan to change the landscaping or **undertake any other kind of work, make sure you advise the people involved** so they do not damage your septic system. As well, if you shovel or blow snow from part of your lot, **do not let the snow accumulate on top of your septic system**. The overload may damage it. To prevent this from happening, mark or indicate the location of your system's components.

About your home

Your home must be equipped with an air vent that is in proper working order and the plumbing must comply with the applicable standards of the building code. Premier Tech Aqua strongly recommends using a 100 mm Ø (4")

pipe for the air vent. Any change in the use of your home or any modification to your DiUV Self-cleaning disinfection unit must be authorized by local authorities, and Premier Tech Aqua must be advised. If this condition is not fully respected, the warranty for your DiUV Self-cleaning disinfection unit will be null and void.

Electrical connections

The electrical connections for the DiUV Self-cleaning disinfection unit and the alarm float must be executed by a licensed electrician. As well, use only watertight screw-in connections with the electrical connection box.

Use two (2) separate circuit-breakers, one to operate the DiUV Self-cleaning disinfection unit and the other to connect the alarm box. Do not connect anything else to these circuit-breakers (for example, a household appliance). They must be used exclusively for the DiUV Self-cleaning disinfection unit and the alarm box.

Warning regarding the start up of the DiUV Self-cleaning disinfection unit

Once the unit is plugged in, the new UV lamps may take from a few moments to several hours to reach full power. Having a UV lamp malfunction alarm is normal with a new system (or with newly installed lamps) until the lamps have reached full power.

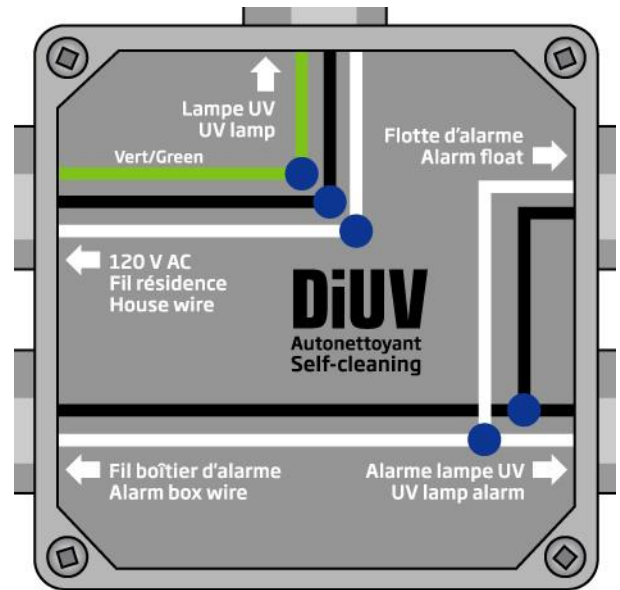

According to Article 87.16 of the *Regulation respecting wastewater disposal systems for isolated dwellings (Q-2, r.22)*, in the case of an ultraviolet disinfection system, it is prohibited to not connect, to disconnect, or to not replace a lamp forming part of the system.

3. DiUV Self-cleaning attributes

3.1. Visual and audio alarm systems

The DiUV Self-cleaning disinfection unit can generate 2 types of alarm connected to the same box. The box must be installed inside the residence such that an alarm can be heard as soon as it is activated. The operation of these 2 types of alarm is presented below.

High water level alarm / UV lamp malfunction alarm

The red indicator lights up when the water level in the tank of the DiUV Self-cleaning disinfection unit is unusually high or when the UV unit malfunctions. If an alarm is activated, contact Premier Tech Aqua’s after-sales service department because the incident has to be checked. To silence the alarm, press the “**SILENCE**” button.



The “**TEST**” button lets you check that the alarm system is functional. During a test, the red indicator should light up and the audio alarm should be heard.

In the event of a power failure, the alarm system continues to function on an emergency 9-volt alkaline battery (not supplied). The use of a rechargeable battery is not recommended.

NOTE: Replace the emergency battery every 12 months and each time an alarm is activated or each time there is a power failure. If the battery is weak, short beeps will be heard at a frequency of one beep per minute. Replace the battery immediately when this occurs.

To replace the 9-volt battery:

- Disconnect the alarm box and remove it from the wall (the battery must be inserted on the side of the box);
- Open the battery cover and replace the battery with a 9-volt alkaline type;

- Close the battery cover reinstall the box on the wall and reconnect it;
- If the alarm is activated, press the “**RESET/TEST**” button to initialize it.

4. Maintenance

4.1. Septic tank

Empty your septic tank regularly. This helps keep your septic system in proper working order. The standards regarding the pumping of septic tanks must be respected, as prescribed in the *Regulation respecting wastewater disposal systems for isolated dwellings (Q-2, r.22)*.

If your home is equipped with a garbage disposal system or a disposal pump, we strongly recommend that you empty your septic tank more often. The use of this type of device increases the amount of sludge in the septic tank.

We recommend that you keep proof of the pumping out of your septic tank (invoice) with this owner's manual so as to keep a record of complete septic system maintenance.

4.2. Advanced secondary treatment system

The maintenance of your Ecoflo® Biofilter is carried out by our local WALTER Wastewater Treatment Services partner network. This service includes a visual inspection of all components and verification of operation, as well as maintenance of the filtering media. **Easy access to your system's lid is essential for maintenance and for filtering media replacement purposes.** You will be given a maintenance record after each inspection, which you should keep with this manual in a safe place.

For all other advanced secondary treatment systems, please refer to the manufacturer's instructions and to Article 3.3 of the *Regulation respecting wastewater disposal systems for isolated dwellings (Q-2, r.22)*.

4.3. DiUV Self-cleaning disinfection unit

According to Article 87.16 of the *Regulation respecting wastewater disposal systems for isolated dwellings (Q-2, r.22)*, every tertiary treatment system with disinfection **must be installed, used and maintained in accordance with the manufacturer's manuals.**

The maintenance of the DiUV Self-cleaning disinfection unit will be done twice a year by our local WALTER Wastewater Treatment Services partner network. Note that the unit's 2 UV lamps will be replaced once a year. You will be given a maintenance record after each inspection, which you should keep with this manual in a safe place.

5. Sampling

According to Article 87.30.1 of the *Regulation respecting wastewater disposal systems for isolated dwellings (Q-2, r.22)*, **the owner of a tertiary treatment system with disinfection must, at least once per 6-month period, have a sample of the system's effluent analyzed to determine the concentration of fecal coliforms.** The owner must send the analysis reports within 30 days of their receipt to the municipality in whose territory the treatment system is situated. In addition, the owner must keep the reports for 5 years and make them available to the Minister's request.

Premier Tech Aqua also provides an effluent analysis service every 6 months.

6. What to do in case of...

6.1. An activated alarm

If an alarm on your DiUV Self-cleaning disinfection unit is activated, unrelated to a power failure, contact Premier Tech Aqua's after-sales service department so the problem can be identified and corrected.

6.2. A prolonged power failure

If a power failure that occurs during winter is prolonged, protect the components of your septic system against freezing. If you have any questions to restart your DiUV Self-cleaning disinfection unit, contact Premier Tech Aqua's after-sales service department.

6.3. Flooding

Certain sites are prone to flooding or to rises in groundwater levels. This can lead to a malfunction in your septic system or alter the performance of your DiUV Self-cleaning disinfection unit. If this should happen, contact Premier Tech Aqua's After-Sales Service Department.

6.4. Odours

The position of the air vent, as well as other factors unrelated to the wastewater treatment system itself, can prevent proper dispersion of septic gases and lead to odours. If this happens, contact Premier Tech Aqua's After-Sales Service Department for solutions.

6.5. Backflow

Backflow rarely occurs. If it happens, the septic tank is usually the cause. Your septic tank installer or septic tank pumper can generally take care of the situation.

6.6. Winter closing of residences

If you close your residence (i.e. close the circuit-breaker) during a potential freezing period, you must contact Premier Tech Aqua's After-Sales Service Department to help establish the appropriate procedure. In doing so, you will ensure a longer life for your DiUV Self-cleaning disinfection unit.

If you have any questions or comments, do not hesitate to contact Premier Tech Aqua at 1 800 632-6356.



 **1 800 632-6356**
 418 862-6642
pta@premiertech.com
PREMIERTECHAQUA.COM

The information contained in this document is based upon the latest information available at the time of publication and is designed to provide you with a general introduction to our products. We make no warranties or representations as to its accuracy. We are continually updating and improving our products and reserve the right to amend, discontinue, alter or change specifications and prices without prior notice. Ecoflo® is a brand of Premier Tech Ltd. The Ecoflo® Biofilter is protected under patents: CA2499637; US7097768; ES2285173; EP1539325 (BE, FR). Notice issued on 2016-01-12. For current data regarding all patent application(s) and patent(s) for this product or any part thereof, consult the website patentmarking.premiertech.com (references: 3685).

© Premier Tech Ltd. 2016

DiUV Self-cleaning disinfection unit certificate of warranty

1. PREAMBLE

Premier Tech Technologies Ltd. (hereinafter called "Premier Tech") is proud to provide its customers with an exclusive wastewater treatment system guaranteed by an innovative Warranty.

For the application and interpretation of this Warranty, "Customer" shall mean the person who has purchased a **DiUV Self-cleaning disinfection unit** (hereinafter called "Initial Purchaser"), as well as any subsequent purchaser (hereinafter called "Subsequent Purchaser(s)"), in accordance with the provisions of Section 8 of this Warranty. "Successor(s)" shall mean any other person entitled to exercise the same rights as the Customer under the law.

2. NATURE OF THE WARRANTY

The following warranty is conditional to and only applies if the **DiUV Self-cleaning disinfection unit** has been installed according to the installation, maintenance and operation instructions as described in the Installation Guide and the Owner's Manual.

2.1 Polyethylene tank

Premier Tech warrants the polyethylene tank of the **DiUV Self-cleaning disinfection unit** (parts and labour) against any manufacturing defect for a period of two (2) years from the date of purchase by the Initial Purchaser (proof of purchase required).

2.2. Other components

Premier Tech also warrants all other components of the **DiUV Self-cleaning disinfection unit** against any manufacturing defect for a period of two (2) years (parts only), from the date of purchase by the Initial Purchaser (proof of purchase required). The first year of the warranty also covers the labour.

This conventional warranty is given by Premier Tech to its customers in addition to the legal warranties and is expressly limited to the text of this certificate.

3. NOTICE

For this Warranty to be valid, the Customer must notify Premier Tech in writing immediately upon the appearance of any indication of an anomaly or irregularity in the **DiUV Self-cleaning disinfection unit**.

Such notice shall be mailed to Premier Tech Head Office at 1, avenue Premier, Rivière-du-Loup, Québec, G5R 6C1, CANADA or by facsimile at (418) 862-6642.

Upon receipt of this notice, Premier Tech shall examine the situation and, if necessary, take appropriate corrective measures in accordance with the terms of this Warranty.

4. GENERAL EXCLUSIONS

The following damages or problems are excluded from the warranty:

- (a) Any damage or problem caused by a fortuitous event or "force majeure," such as, without limiting the generality of the foregoing, an earthquake, a flood, frost, hurricane, landslide, explosion or dynamiting;
- (b) Any damage or problem caused by the fault or act of a third party including, without limiting the generality of the foregoing, the execution of landscaping work;
- (c) Any damage or problem arising from a defective installation carried out by a person trained by Premier Tech, or any installation, modification, correction or

addition carried out by a person not trained by Premier Tech;

(d) Any damage or problem arising from any installation, modification, correction or addition to the treatment system carried out after installation of the **DiUV Self-cleaning disinfection unit** without prior written approval from Premier Tech;

(e) Any damage or problem caused by the use of a septic tank that does not comply with the applicable regulations and/or with Premier Tech's specifications, as described in the Owner's Manual;

(f) Any damage or problem, if it is shown that the usage of the **DiUV Self-cleaning disinfection unit** was not in accordance with the instructions and guidelines described in the Owner's Manual;

(g) Any damage or problem, if the maintenance of the **DiUV Self-cleaning disinfection unit** was not carried out by a person authorized by Premier Tech, in accordance with the Maintenance Agreement;

(h) Any damage or problem caused by an omission or act of the Customer or the Customer's Successors including, without limiting the generality of the foregoing, refusal to allow access to the system for maintenance;

(i) Any damage or problem, if it is found that the Customer or the Customer's Successors have modified or changed the use of the property serviced by the **DiUV Self-cleaning disinfection unit** resulting in the alteration of the nature or quality of wastewater being treated and/or that constitutes a violation of the applicable regulations;

(j) Any damage or problem caused by and/or resulting from the work carried out to access to the **DiUV Self-cleaning disinfection unit**, including, without limiting the generality of the foregoing, excavation, snow removal or demolition;

(k) Any damage or problem resulting from the condition of the site or of the soil and not reported or not properly reported to Premier Tech by the Customer or the person undertaking the site/soil investigation.

5. PARTICULAR EXCLUSIONS

It is further expressly understood that the Customer may not carry out or cause to be carried out any repair or verification of the **DiUV Self-cleaning disinfection unit** sold to him, or attempt to carry out any work or to apply any corrective measures whatsoever to said work, before notifying Premier Tech in accordance with the provisions of Section 3 of this Warranty and before Premier Tech has visited the site, within a reasonable time following receipt of said notice, to assess the situation.

If the Customer carries out or causes to be carried out repairs, or attempts to repair or to apply corrective measures of any kind whatsoever to the **DiUV Self-cleaning disinfection unit** sold to him without prior authorization by Premier Tech, this Warranty shall be considered null and void and Premier Tech shall be considered completely discharged from any and all of its obligations under this Warranty.

DiUV Self-cleaning disinfection unit certificate of warranty

6. INDEMNITIES AND DAMAGES

In accordance with Sections 3 and 4, Premier Tech's liability and obligations regarding any corrective measure carried out or any attempt to correct an indicated problem shall be limited to replacing of one or several components of the **DiUV Self-cleaning disinfection unit** and to supplying the required labour, if applicable.

7. LIMITATION OF LIABILITY

Premier Tech's compensation or indemnification obligation shall be limited to the provisions of Section 6 of this Certificate of Warranty and Premier Tech shall not be held liable for any other damage or loss that may have been suffered or incurred by the Customer or any third party in connection with the **DiUV Self-cleaning disinfection unit**.

8. TRANSFER OF OWNERSHIP

In the event of transfer of ownership, sale, assignment or disposal in any way whatsoever of the Customer's property to a third party, this Warranty shall continue to apply if and only if the Subsequent Purchaser or the Successor confirms, by forwarding the attached "Notice of New Property Owner" to Premier Tech within a reasonable delay, that he/she is the new owner of the property, he/she understands and is aware of the content of this Certificate of Warranty and accepts its terms and conditions.

The person who proceeds with the transfer, sale, assignment or disposal of any way whatsoever of the property undertakes to hand over to the Subsequent Purchaser or the Successor the Certificate of Warranty provided upon completion of the work, as well as the Owner's Manual and, if applicable, the Maintenance and Environmental Monitoring Program for the **DiUV Self-cleaning disinfection unit**.

Failure to abide by the terms and conditions of Section 8 of this Certificate of Warranty may, at Premier Tech's discretion, render it invalid or to be rejected.

9. INSPECTION

The Customer and/or the Customer's Successors shall allow Premier Tech or its duly authorized representatives to carry out all necessary monitoring and inspections, as required, for implementation of this Warranty.

If the Customer and/or the Customer's Successors notify Premier Tech of an alleged defect or malfunction of the **DiUV Self-cleaning disinfection unit** and that, after inspection, it is found that no such defect or malfunction exists, or, that such defect or malfunction is excluded from or does not apply to the Warranty, a minimum charge of \$150.00 plus direct expenses shall be paid by the Customer and/or the Customer's Successors for the cost of the inspection.

10. INTERPRETATION

The terms and conditions of this Warranty shall be interpreted according to and governed by the provisions of this Warranty and the legislation in effect in the Province of Quebec.

11. PRIORITY OF THE CERTIFICATE OF WARRANTY

This Warranty supersedes any contract or understanding, written or verbal, entered into between the Customer and Premier Tech. In the event of contradiction between this Warranty and any other documents and/or contracts entered into between the Customer and Premier Tech, this Warranty shall prevail.

12. PURCHASERS AND SUCCESSORS

Subject to the provisions of this Warranty and especially those of Section 8, this Warranty shall continue to be valid for Subsequent Purchasers and Successors and shall continue to have full effect until the end of the agreed Warranty period provided for in Section 2 of this Certificate.

Notice of new property owner

Name of previous owner: _____

I, the undersigned _____ hereby declare that I have acquired the property located at

Civic number	Street	City	Province or State
--------------	--------	------	-------------------

Postal code	Phone number
-------------	--------------

I have read and I understand the warranty provided by Premier Tech Technologies Ltd for the **DiUV Self-cleaning disinfection unit**. I wish to benefit from this Warranty for the remaining period, if any, and from the date of the transfer of ownership, that is _____; I accept to be bound by this warranty and by any and all of the clauses, undertakings and conditions set forth therein; I have had the opportunity to examine the **DiUV Self-cleaning disinfection unit** and declare myself satisfied with it at the time of this transfer. I ask Premier Tech Technologies Ltd to take note of this transfer of ownership.

Signature: _____ Date: _____

Name of new owner: _____

(Please print)

Language preference: English French

New owner's e-mail address: _____