



Owner's  
manual

# REWATEC™

UV disinfection unit (DiUV)



Certified  
to BNQ  
standard  
NQ 3680-910



## TABLE OF CONTENTS

<b>PREAMBLE</b> .....	<b>5</b>
<b>1. Operating principle</b> .....	<b>5</b>
1.1 Main components and functions .....	5
<b>2. Operating guidelines</b> .....	<b>6</b>
2.1 Types of wastewater that can be treated .....	6
2.2 Recommendations .....	7
2.3 What you need to know .....	8
<b>3. Rewatec UV disinfection unit (DiUV) features</b> .....	<b>8</b>
3.1 Wi-Fi, visual, and audio alarm systems .....	8
<b>4. Maintenance</b> .....	<b>9</b>
4.1 Primary treatment and effluent filter .....	9
4.2 Advanced secondary treatment system .....	9
4.3 Rewatec UV disinfection unit (DiUV) .....	9
<b>5. Sampling</b> .....	<b>10</b>
<b>6. What to do in case of..</b> .....	<b>10</b>
6.1 An activated alarm .....	10
6.2 A prolonged power outage .....	10
6.3 Flooding .....	10
6.4 Odours .....	10
6.5 Backflow .....	10
<b>Annex 1   Certificate of warranty for the Rewatec UV disinfection unit (DiUV)</b> .....	<b>11</b>
<b>Annex 2   Notice of change of property ownership</b> .....	<b>13</b>
<b>Annex 3   Annual maintenance program and warranty activation form</b> .....	<b>13</b>



# Owner's manual |

## Rewatec UV disinfection unit (DiUV)

Congratulations on purchasing the **Rewatec UV disinfection unit (DiUV)**! When you choose the Rewatec DiUV, you are choosing to help protect water sources and to preserve our planet for future generations. The Rewatec DiUV paired with the Ecoflo compact biofilter constitutes a tertiary treatment system with disinfection certified Class V according to the NQ 3680-910 standard. The system includes a septic tank, an effluent filter, the Ecoflo compact biofilter, and the Rewatec DiUV.

This manual contains information on the operation, operating guidelines, maintenance, and warranties of the Rewatec DiUV. All information relating to the operation, operating guidelines, and maintenance of the septic tank, effluent filter, and Ecoflo compact biofilter unit can be found in the Ecoflo compact biofilter owner's manual. For additional information, please contact Premier Tech at 1-800-632-6356 or visit our website at [PT-WaterEnvironment.com](http://PT-WaterEnvironment.com).

## 1. OPERATING PRINCIPLE

The purpose of the Rewatec UV disinfection unit (DiUV) is to reduce the concentration of fecal coliforms below 200 CFU/100 m<sup>3</sup>. The Rewatec DiUV does this by exposing microorganisms to a dose of ultraviolet rays. The dose depends exposure time and the intensity of the rays. The applied flowrate on the Rewatec DiUV ensures an optimal exposure time that provides the dose needed to disinfect effluent.

### 1.1 MAIN COMPONENTS AND FONCTIONS

#### A | UV unit

- includes the UV lamp and the quartz sleeve
- exposes wastewater to UV rays
- equipped with quick disconnects for easy lamp retrieval
- includes flexible hoses for connections between the pump and outlet

#### B | Pump assembly

- injects pressurized water into the UV unit
- equipped with a mesh filter
- equipped with an entry valve that can isolate the UV unit during servicing

#### C | Float tree

- pre-wired to the pump assembly and junction boxes
- manages pumping frequency
- detects high water levels

#### D | Wi-Fi alarm box

- warns the homeowner of abnormalities in the septic installation

#### E | Junction box (2)

- protects electrical connections

#### F | Watertight box

- houses the Rewatec DiUV's controller

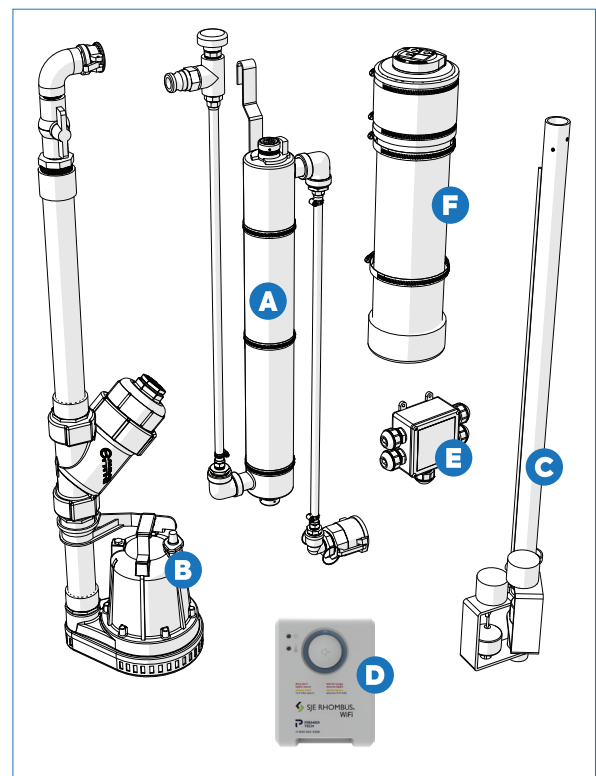

<sup>1</sup> The maximum concentration for tertiary treatment systems with UV disinfection must be divided by a factor of 10 to take into account the reactivation of fecal coliforms after disinfection.

## Capacity of the Rewatec UV disinfection unit

Number of bedrooms	Total daily flow (litres)	Number of UV disinfection unit required
1	540	1
2	1,080	
3	1,260	
4	1,440	
5	1,800	
6	2,160	
Other buildings ruled by Q-2, r.22 <sup>2</sup>	3,240	

## 2. OPERATING GUIDELINES

### 2.1 TYPES OF WASTEWATER THAT CAN BE TREATED

#### Using a secondary or advanced secondary treatment system

Domestic wastewater (for example, wastewater from an onsite installation).

#### Using the Rewatec UV disinfection unit (DiUV)

Domestic wastewater coming from an advanced secondary treatment system certified in accordance with the NQ 3680-910 standard for an advanced secondary level (Class III). To be installed in Québec at a flow rate below 3,240 L/d, the treatment chain consisting of an advanced secondary treatment and the Rewatec DiUV must be certified in accordance with the NQ 3680-910 standard.

#### Water supply source quality analysis

Premier Tech recommends conducting a drinking water test. Drinking water should respect the following levels:

#### For the self-cleaning Rewatec UV disinfection unit (DiUV)

Hardness < 500 mg/L
---------------------

#### For the classic Rewatec UV disinfection unit (DiUV)

Water quality and minerals	Level
Iron	< 0.3 ppm (0.3 mg/L)
Hardness	< 7 gpg (120 mg/L)
Manganese	< 0.05 ppm (0.05 mg/L)
Tannins	< 0.1 ppm (0.1 mg/L)

#### Drinking water filtration system

Unless it is a water softener, backwash from a home drinking water filtration system must never enter a wastewater system equipped with the Rewatec UV disinfection unit.

#### Water softener

Premier Tech recommends the following actions for homes with water softener systems.

- Start with a water test:
  - 1) Have your drinking water analyzed by an accredited laboratory.
  - 2) Have a drinking water treatment professional design your system based on the results of these analyses.
  - 3) Ensure the system you install complies with NSF/ANSI standard 44.

<sup>2</sup> Q-2, r.22 is applicable only in Quebec.

- To reduce the frequency of backwash, the volume of water required, and the amount of salt used, we recommend that you:
  - Use a demand-initiated regeneration (DIR) water softener system.
  - Avoid all-in-one solutions and choose drinking water treatments according to the specific contaminants to be removed (for example, filtering for iron, manganese, etc.).
  - Use an upflow softener system.
  - Use less than 6 lb of salt/ft<sup>3</sup> of resin if you use a downflow softener system.
  - Have the system calibrated by a professional to ensure optimal performance.
  - Follow the instructions in your system’s operation and maintenance guide.

Make sure that your drinking water professional coordinates with a Premier Tech Water and Environment expert, who will assist you with your project.

## 2.2 RECOMMENDATIONS

NEVER discharge any of the following items into your septic system:

- backwash from a drinking water filtration system other than a water softener
- oils and greases
- petroleum products
- paints, solvents, and any other toxic substance
- wax, resins, and any septic tank additives
- anything not easily biodegradable (for instance, coffee beans, cigarette butts, sanitary napkins, tampons, condoms, cotton swabs, etc.)
- pesticides



Premier Tech also strongly recommends the following precautions:

- NEVER open the access lid or enter the Rewatec UV disinfection unit (DiUV) unless authorized.
- NEVER cover or bury any septic system component access lids. Once the final landscaping is complete, any lid must be 50 mm (2”) above the surface (grass included).
- NEVER connect a drainage pipe, roof gutter, sump/drainage pump, or air condition drain to your septic system.
- NEVER operate a vehicle or place any item weighing more than 225 kg (500 lb) within 2 m (6.7’) from the edge of the lid<sup>3</sup>.
- NEVER let any debris or material accumulate over your septic system. The excess weight could damage your septic system and void your warranty.
- NEVER use an automatic toilet cleaner.
- NEVER add extensions to the access of the Rewatec UV disinfection unit (DiUV).



**Warning: do not handle!**

The handling of the Rewatec UV disinfection unit is dangerous for your health and carries a serious risk of eye injury.

**For more information, please contact Premier Tech at 1 800 632-6356.**

<sup>3</sup> The minimum distance to respect for concrete Ecoflo compact biofilter units integrated with the Rewatec UV disinfection unit (DiUV) is 3 m (10’), starting from the edge of the lid. The minimum distance for polyethylene Ecoflo compact biofilter units with the same configuration is 4 m (13’).

---

## 2.3 WHAT YOU NEED TO KNOW

### Owner's responsibility

The owner must respect all existing laws and regulations regarding the quality of the effluent from the system and its discharge into the environment.

### Keep heavy weights off your system

Never operate a vehicle or place objects weighing more than 225 kg (500 lb) within 2 m (6.7') from the edge of the lid<sup>4</sup>. Advise anyone undertaking landscaping work on your property of the location of your septic system. Do not let any material or debris accumulate over your septic system. Failure to follow any of these recommendations can result in damage to your septic system. Premier Tech recommends to keep track of your septic system's components or to mark their location.

### About your home

Your home must be equipped with an air vent that is in proper working order. Any plumbing must comply with applicable building code standards. Premier Tech strongly recommends using a 100 mm Ø (4") pipe for the air vent. You must notify Premier Tech and get authorization from local authorities before undertaking any change in the use of your home or any modification to the Rewatec UV disinfection unit. If this condition is not fully respected, the warranty of the Rewatec UV disinfection unit (DiUV) will be voided at Premier Tech's discretion.

### Electrical connections

The electrical connections for the UV disinfection unit (DiUV) and the alarm float must be made by a licensed electrician. They must only use watertight screw-in connections for the electrical connection box.

The components must use two separate circuit-breakers: one to operate the Rewatec DiUV, and the other to connect the alarm box. Do not connect anything else to these circuit-breakers (for example, household appliances). These circuit-breakers must be used exclusively for the Rewatec DiUV and the alarm box.

### Warning regarding the start-up

Once the unit is plugged in, the UV lamps may take up to several hours to reach full power. With new systems or newly-installed UV lamps, expect to hear a UV lamp malfunction alarm until the lamps have reached full power.

In Québec, according to Article 87.16 of the *Regulation respecting wastewater disposal systems for isolated dwellings (Q-2, r.22)*, an ultraviolet (UV) disinfection system must be turned on at all times, except during maintenance. It is prohibited to fail to connect, to disconnect, or to fail to replace a lamp forming part of a UV disinfection system. These recommendations apply in all territories where the Rewatec UV disinfection unit is commercialized.

## 3. REWATEC UV DISINFECTION UNIT (DIUV) FEATURES



### 3.1 WI-FI, VISUAL, AND AUDIO ALARM SYSTEMS

The Rewatec UV disinfection unit (DiUV) can generate two types of alarms that are both connected to the same box. The box must be installed inside the residence to make sure the alarm can be heard as soon as it is activated. The function of these two alarms is presented below.

#### Water level alarm inside the Ecoflo compact biofilter

A **red** light flashes on and an alarm triggers when the water level inside the Ecoflo compact biofilter is unusually high. Troubleshooting must be performed.

#### UV controller malfunction alarm

An **amber** light flashes on and an alarm triggers when the UV controller malfunctions. When the Rewatec DiUV is integrated within the Ecoflo compact biofilter unit, this alarm triggers whenever there is an issue with the UV bulb, the UV controller, or the alarm relay. If the Rewatec DiUV is a standalone unit, this type of alarm may also indicate the presence of water in the system's tank. In all cases, troubleshooting must be performed.

The alarm box's alarm can be silenced with the alarm box's "SILENCE" button. Immediately contact Premier Tech at 1 800 632-6356 to address the cause of the incident.

---

<sup>4</sup> The minimum distance to respect for concrete Ecoflo compact biofilter units integrated with the Rewatec UV disinfection unit (DiUV) is 3 m (10'), starting from the edge of the lid. The minimum distance for polyethylene Ecoflo compact biofilter units with the same configuration is 4 m (13').



The alarm box is also Wi-Fi enabled and allows email or SMS notifications whenever the alarm triggers. To configure and activate the Wi-Fi function, please refer to the quick guide provided with your alarm box or contact Premier Tech's at 1 800 632-6356 for assistance. The activation of the Wi-Fi feature will also allow Premier Tech to receive email notifications whenever there is an issue with the Rewatec DiUV. We will then contact you to address the cause of the incident.

In the event of power failure, the alarm system relies on an emergency battery integrated within the alarm system. The button on the alarm box can also be used to ensure the alarm is functional. During a test, you should see the red light activate, hear the alarm, and, if the Wi-Fi function is activated and configured, you and Premier Tech should both receive a notification by email or SMS, depending to your configuration.

## 4. MAINTENANCE

### 4.1 PRIMARY TREATMENT AND EFFLUENT FILTER

Under normal operating conditions, as described in this manual, an effluent filter that complies with BNQ standard 3680-905 should perform efficiently for many years. It must be cleaned every time the primary/septic tank is emptied. A service partner or qualified third party as referred to in section 1x.2) of the *Regulation respecting wastewater disposal systems for isolated dwellings (Q-2, r.22)* can clean the effluent filter while performing annual maintenance. For 100% coco filter Ecoflo treatment systems combined with the Rewatec UV disinfection unit (DiUV), the flow regulator must be cleaned to remove any particles or residue that may have stuck to the surface.

Empty your septic tank regularly. This will help keep your septic system in proper working order. The standards regarding the pumping of septic tanks must be respected, as described in the *Regulation respecting wastewater disposal systems for isolated dwellings (Q-2, r.22)*.

### 4.2 ADVANCED SECONDARY TREATMENT SYSTEM

Maintenance of the Ecoflo compact biofilter is carried out by a trusted local Premier Tech partner or by a qualified third party as referred to in section 1x.2) of the *Regulation respecting wastewater disposal systems for isolated dwellings (Q-2, r.22)*. Maintenance includes a visual inspection of all septic system components, a performance test to verify the system's operation, and maintenance of the filtering medium. Easy access to your system's lid is essential to perform annual maintenance and to renew its filtering medium once it expires. To receive a maintenance report after each inspection, simply contact Premier Tech at 1 800 632-6356 to provide a valid email address. Maintenance reports should also be kept inside this manual as proof of maintenance and kept in a safe place.

For all other advanced secondary treatment systems, please refer to the manufacturer's instructions and to Article 3.3 of the *Regulation respecting wastewater disposal systems for isolated dwellings (Q-2, r.22)*.

### 4.3 REWATEC UV DISINFECTION UNIT (DIUV)

According to Article 87.16 of the *Regulation respecting wastewater disposal systems for isolated dwellings (Q-2, r.22)*, every tertiary treatment system with UV disinfection must be installed, used, and maintained in accordance with the manufacturer's guides and manuals.

The maintenance of the Rewatec DiUV must be performed twice a year by a trusted Premier Tech partner. Please note that the unit's UV lamps must be replaced once a year. To receive a maintenance report after each inspection, simply contact Premier Tech at 1 800 632-6356 to provide a valid email address. Maintenance reports should also be kept inside this manual as proof of maintenance and kept in a safe place.

---

## 5. SAMPLING

According to Article 87.30.1 of the *Regulation respecting wastewater disposal systems for isolated dwellings (Q-2, r.22)*, the owner of a tertiary treatment system with disinfection must have a sample of their system's effluent tested every six months. The owner must send test results within 30 days of their receipt to the local municipality in which the treatment system is installed. The owner must also keep their own copy of the reports for five years to be made available to the Minister upon request.

## 6. WHAT TO DO IN CASE OF...



### 6.1 AN ACTIVATED ALARM

If an alarm on the Rewatec UV disinfection unit (DiUV) is activated for reasons unrelated to a power outage, please contact Premier Tech at 1-800-632-6356 for immediate assistance. If the alarm system's Wi-Fi feature is activated and configured to your phone or email, Premier Tech will contact you to assist you with the situation.



### 6.2 A PROLONGED POWER OUTAGE

Premier Tech recommends certain precautions in the event of a prolonged power outage in winter to protect your septic installation and components of the Rewatec UV disinfection unit (DiUV) against freezing. Please contact Premier Tech at 1-800-632-6356 to learn more.



### 6.3 FLOODING

Certain sites are prone to flooding or to rising groundwater levels. This can lead to malfunctions in your septic system and may alter the performance of the Rewatec UV disinfection unit (DiUV). If this happens, please contact Premier Tech at 1-800-632-6356.



### 6.4 ODOURS

The position and physical state of the air vent, as well as other factors unrelated to the wastewater treatment system itself, can prevent the proper dispersion of septic gases and lead to odours. If this happens, please contact Premier Tech at 1-800-632-6356.



### 6.5 BACKFLOW

Backflow rarely occurs. When it does, a full septic tank is often the cause. Your septic tank's installer or local septic expert can generally take care of the situation. Please contact them for more details.

**If you have any questions or comments, please do not hesitate  
to contact Premier Tech at 1 800 632-6356.**



### PT Water and Environment

+1 800 632-6356

info.ptwe.na@premiertech.com

PT-WaterEnvironment.com



The information contained in this document was up-to-date and consistent with the information available at the time of publication. Premier Tech Ltd. makes no warranties or representations as to its accuracy. Because of its continuous improvement policy, Premier Tech Ltd. and its affiliated companies reserve the right to change and/or discontinue the manufacture of any product and/or modify technical data and prices, for any reason whatsoever and at its sole discretion, without further notice and without liability to anyone in this regard. ECOFLO®, REWATEC™, PREMIER TECH®, and PREMIER TECH & DESIGN™ are trademarks of Premier Tech Ltd. or its affiliates.

© 2025 Premier Tech Ltd. All rights reserved.

# ANNEX 1 | CERTIFICATE OF WARRANTY FOR THE REWATEC UV DISINFECTION UNIT (DIUV)

## 1. PREAMBLE

Premier Tech Technologies Ltd. (hereinafter called "Premier Tech") is proud to provide its customers with an exclusive wastewater treatment system guaranteed by an innovative Warranty.

For the application and interpretation of this Warranty, "Customer" shall mean the person who has purchased the Rewatec UV disinfection unit (DiUV) (hereinafter called "Initial Purchaser") as well as any subsequent purchaser (hereinafter called "Subsequent Purchaser(s)"), in accordance with the provisions of Section 8 of this Warranty. "Successor(s)" shall mean any other person entitled to exercise the same rights as the Customer under the law.

## 2. NATURE OF THE WARRANTY

The following warranty is conditional to and only applies if the Rewatec UV disinfection unit (DiUV) has been installed according to the installation, maintenance and operation instructions described in the installation guide and owner's manual.

### 2.1 Polyethylene tank

Except as provided in section 2.4 below, Premier Tech warrants the polyethylene tank of the Rewatec UV disinfection unit (DiUV) (parts and labour) against any manufacturing defect for a period of ten (10) years from the date of purchase by the Initial Purchaser (proof of purchase required).

### 2.2 Other components

Premier Tech also warrants all other components of the UV disinfection unit (DiUV) against any manufacturing defect for a period of two (2) years (parts and labour) from the date of purchase by the Initial Purchaser (proof of purchase required). The first year of the warranty also covers the labour.

This conventional warranty is provided by Premier Tech to all its customers in addition to the legal warranties and is expressly limited to the text of this certificate.

### 2.3 Wi-Fi Alarm Box

In the event of a UV lamp or high level alarm in the Ecoflo compact biofilter unit, Premier Tech warrants that a service partner will be present on the site within 24 hours from the time that Premier Tech receives the alarm message, provided that the resolution of this alarm requires an intervention on site and that the Client has a Wi-Fi alarm box. Premier Tech cannot be held responsible in the event of a signal interruption between the alarm box and the Wi-Fi router or if the customer refuses to carry out the initial start-up of the alarm box.

### 2.4 Pump, floats and junction box

The pump, floats, alarm box and junction box included with the UV disinfection unit (DiUV) are guaranteed for three (3) years (parts and labor), from the date of purchase by the Initial Purchaser (proof of purchase required).

## 3. NOTICE

For this Warranty to be valid, the Customer must notify Premier Tech in writing immediately upon the appearance of any indication of an anomaly or irregularity in the UV disinfection unit (DiUV).

Such notice shall be mailed to the Premier Tech World Headquarters at 1, avenue Premier, Rivière-du-Loup, Québec, G5R 6C1, CANADA, by fax at 418 862-6642 or by e-mail at [info.ptwe.na@premiertech.com](mailto:info.ptwe.na@premiertech.com).

Upon receipt of this notice, Premier Tech will evaluate the situation and, if necessary, take the appropriate corrective measures as per the terms of this Warranty.

## 4. GENERAL EXCLUSIONS

The following damages or problems are excluded from the warranty:

- Any damage or problem caused by a fortuitous event or "force majeure", such as, without limiting the generality of the foregoing, an earthquake, a flood, frost, hurricane, landslide, explosion or dynamiting;
- Any damage or problem caused by the fault or act of a third party including, without limiting the generality of the foregoing, the execution of landscaping work;
- Any damage or problem arising from any installation, modification, correction or addition to the treatment system carried out after installation of the UV disinfection unit (DiUV) without prior written approval from Premier Tech;
- Any damage or problem caused by the use of a septic tank not compliant with the applicable regulations and/or with Premier Tech's instructions and guidelines described in the owner's manual;
- Any damage or problem, if it is shown that the usage of the UV disinfection unit (DiUV) was not used, operated or installed in accordance with the instructions and guidelines described in the owner's manual;

- Any damage or problem, if the maintenance of the UV disinfection unit (DiUV) was not carried out by a person authorized by Premier Tech or by a qualified third party as referred to in section 1x.2) of the *Regulation respecting waste water disposal systems for isolated dwellings (Q-2, r.22)*;
- Any damage or problem caused by an omission or act of the Customer or the Customer's Successors including, without limiting the generality of the foregoing, refusal to allow access to the system for maintenance;
- Any damage or problem, if it is found that the Customer or the Customer's Successors have modified or changed the use of the property serviced by the UV disinfection unit (DiUV) resulting in the alteration of the nature or quality of wastewater being treated and/or constitutes a violation of the applicable regulations;
- Any damage or problem caused by and/or resulting from the work carried out to access to the UV disinfection unit (DiUV), including, without limiting the generality of the foregoing, excavation, snow removal or demolition;
- Any damage or problem resulting from the condition of the site or of the soil that is or was not reported or not properly reported to Premier Tech by the Customer or the person undertaking the site and/or soil investigation.

## 5. PARTICULAR EXCLUSIONS

It is further expressly understood that the Customer may not carry out or cause to be carried out any repair or verification of the UV disinfection unit (DiUV) sold to him before notifying Premier Tech in accordance with the provisions of section 3 of this Warranty and before Premier Tech has visited the site, within a reasonable time following receipt of said notice, to assess the situation.

It is also expressly understood that the Customer may not modify or carry out any corrective measures whatsoever to the UV disinfection unit (DiUV) sold to him before notifying Premier Tech, in accordance with the provisions of section 3 of this Warranty, and before Premier Tech has visited the site, within a reasonable time following receipt of said notice, to assess the situation.

If the Customer carries out or causes to be carried out repairs, or attempts to repair or to apply corrective measures of any kind whatsoever to the UV disinfection unit (DiUV) sold to him without prior authorization by Premier Tech, this Warranty shall be considered null and void and Premier Tech shall be considered completely discharged from any and all of its obligations under this Warranty.

This section does not restrict the Customer from having the manual maintenance of the Ecoflo compact biofilter performed by a qualified third party as referred to in section 1x.2) of the *Regulation respecting waste water disposal systems for isolated dwellings (Q-2, r.22)*.

## 6. INDEMNITIES AND DAMAGES

In accordance with Sections 3 and 4, Premier Tech's liability and obligations regarding any corrective measure carried out or any attempt to correct an indicated problem shall be limited to replacing one or several components of the UV disinfection unit (DiUV) and to supplying the required labour, if applicable.

## 7. LIMITATION OF LIABILITY

Premier Tech's compensation or indemnification obligation shall be limited to the provisions of Section 6 of this Certificate of Warranty and Premier Tech shall not be held liable for any other damage or loss that may have been suffered or incurred by the Customer or any third party about the UV disinfection unit (DiUV).

## 8. TRANSFER OF OWNERSHIP

In the event of a transfer of ownership, sale, assignment or disposal in any way whatsoever of the Customer's property to a third party, this Warranty shall continue to apply if and only if the Subsequent Purchaser or the Successor confirms, by forwarding the attached "Notice of New Property Owner" to Premier Tech within a reasonable delay, informing Premier Tech that he/she is the new owner of the property, he/she understands and is aware of the content of this Certificate of Warranty and accepts its terms and conditions.

The person who proceeds with the transfer, sale, assignment or disposal in any way whatsoever of the property undertakes to hand over the Certificate of Warranty provided upon completion of the work to the Subsequent Purchaser or the Successor as well as the owner's manual and, if applicable, the Maintenance and Environmental Monitoring Program for the UV disinfection unit (DiUV).

Failure to abide by the terms and conditions of Section 8 of this Certificate of Warranty may, at Premier Tech's discretion, render it invalid or to be rejected.

---

## **9. INSPECTION**

The Customer and/or the Customer's Successors shall allow Premier Tech or its duly authorized representatives or third parties to carry out all necessary monitoring and inspections, as required, for the implementation of this Warranty.

If the Customer and/or the Customer's Successors notify Premier Tech of an alleged defect or malfunction of the UV disinfection unit (DiUV) and that, after inspection, it is found that no such defect or malfunction exists or that such defect or malfunction is excluded from or does not apply to the Warranty, a minimum charge of \$200.00 plus direct expenses shall be paid to Premier Tech by the Customer and/or the Customer's Successors for the cost of the inspection.

## **10. INTERPRETATION**

The terms and conditions of this Warranty shall be interpreted in accordance with and governed by the provisions of this Warranty and the legislation in effect in the Province of Québec.

## **11. PRIORITY OF THE CERTIFICATE OF WARRANTY**

This Warranty supersedes any contract or understanding, written or verbal, entered into between the Customer and Premier Tech. In the event of a contradiction between this Warranty and any other documents and/or contracts entered into between the Customer and Premier Tech, this Warranty shall prevail.

## **12. PURCHASERS AND SUCCESSORS**

Subject to the provisions of this Warranty and specifically those of Section 8, this Warranty shall continue to be valid for Subsequent Purchasers and Successors and shall continue to have full effect until the end of the agreed Warranty period provided for in Section 2 of this Certificate.

## ANNEX 2 | NOTICE OF CHANGE OF PROPERTY OWNERSHIP

THIS FORM MUST BE RETURNED TO PREMIER TECH  
 1, avenue Premier, Rivière-du-Loup (Quebec) G5R 6C1  
 or [maintenance.ptwe.na@premiertech.com](mailto:maintenance.ptwe.na@premiertech.com)

Have you recently sold a property serviced by a Premier Tech wastewater treatment system? Please complete the information below to the best of your knowledge to ensure a quick and accurate update of the customer file.

<b>Name</b>			
<b>You are the</b>	<input type="checkbox"/> Previous owner <input type="checkbox"/> New owner	<b>Premier Tech customer number</b>	

Site address serviced by a Premier Tech system									
Civic number		Street		City		Province/State		Postal/Zip Code	

<b>Name of the new owner</b>									
------------------------------	--	--	--	--	--	--	--	--	--

Postal address (if different than the site where the system is installed)									
Civic number		Street		City		Province/State		Postal/Zip Code	

<b>Preferred language of correspondence</b>	<input type="checkbox"/> French <input type="checkbox"/> English	<b>Preferred method of correspondence</b>	<input type="checkbox"/> Email <input type="checkbox"/> Mail
---	---	---	---

<b>Phone</b>		<b>Phone</b>		<b>Email</b>	
	(cellular)		(other)		

I hereby declare that the residence serviced by a Premier Tech treatment system located at the above address changed ownership on this date:

\_\_\_\_\_

**Date**

If you are the PREVIOUS owner:	
<input type="checkbox"/> I have provided the system's owner's manual and the included warranty certificate to the new owners. I have informed them that an annual maintenance is required on the system as per local regulation and to maintain the validity of the product's warranties.	
_____ <b>Signature</b>	_____ <b>Date</b>

If you are the NEW owner:	
<input type="checkbox"/> I hereby declare that I have received and read the owner's manual and warranty certificate and agree to abide by their terms and conditions.	
<input type="checkbox"/> I understand that an annual maintenance is required for all treatment systems as per local regulation and that I must renew my annual maintenance contract with the manufacturer every year (at the latest on December 31st of every year) to benefit from the protections of the product's warranty and ensure compliance of my system.	
_____ <b>Signature</b>	_____ <b>Date</b>



## APPENDIX 3 | ANNUAL MAINTENANCE PROGRAM AND WARRANTY ACTIVATION FORM

Dear Customer,

Congratulations on your acquisition of a Premier Tech system! To activate your warranty, please complete and return this document to Premier Tech. This document will also confirm your registration to our Annual Maintenance Program. As required by the local regulation in effect, your registration to the maintenance program must be renewed every year. Premier Tech or a local service contractor will perform the annual maintenance of your system. Please do not hesitate to contact us at **1-800-632-6356** or write to us at [info.ptwe.na@premiertech.com](mailto:info.ptwe.na@premiertech.com) if you have any questions.

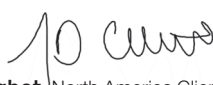
<b>Customer's name</b>				
<b>Address of installation</b>				
Number	Street	City	Province/State	Postal code/Zip code
<b>Mailing address</b>				
Number	Street	City	Province/State	Postal code/Zip code
<b>Phone</b>		<b>E-mail</b>		
Home	Work			
<b>Language</b>		<b>Preferred means of communication</b>		
<input type="checkbox"/> English <input type="checkbox"/> French		<input type="checkbox"/> Email <input type="checkbox"/> Postal service		
<b>NPDES GP4 required</b>				
<input type="checkbox"/> No <input type="checkbox"/> Yes (by checking this box, Premier Tech will cover the sampling service under additional fees)				
<b>Model</b>	<b>Quantity</b>	<b>Installation date</b>	<b>Serial number</b>	<b>Residence type</b> <input type="checkbox"/> New construction <input type="checkbox"/> Secondary
<input type="checkbox"/> Ecoflo compact biofilter				<b>Number of bedrooms</b> 
<input type="checkbox"/> Ecoflo linear biofilter				
<input type="checkbox"/> Classic UV disinfection (DiUV)				<b>Installation type</b> <input type="checkbox"/> Principal <input type="checkbox"/> Repair of existing system
<input type="checkbox"/> Self-cleaning UV disinfection (DiUV)				
<input type="checkbox"/> Nitrogen reduction (ECDn)				<b>If waterfront</b> Please indicate if your property is not accessible by car, and, if so, by which means of transportation you will make available to have the maintenance visit done <input type="checkbox"/> Lake <input type="checkbox"/> Ocean <input type="checkbox"/> River <input type="checkbox"/> Boat <input type="checkbox"/> 4X4 <input type="checkbox"/> Air <input type="checkbox"/> Other _____
<input type="checkbox"/> Disinfection filter (FDi)				
<input type="checkbox"/> Phosphorus removal (DpEC)				
<input type="checkbox"/> Premier Tech sand filter				
<b>Soil test performed by</b>		<b>PREMIER TECH TECHNOLOGIES LTD</b>		
		Represented by  <b>Jean-Daniel Chabot</b> , North America Client Solutions Director		
<b>Plans designed by</b>				
<b>Installer</b>				
<b>Signed in</b>		<b>this</b>		
	City		Date	Owner's signature

### IMPORTANT REMINDER

According to certain regulations in effect, this document must be sent to your municipality as proof of registration with the Premier Tech Maintenance Program. Please inquire with your municipality.

## TERMS & CONDITIONS

### OBLIGATIONS OF PREMIER TECH

1. Premier Tech agrees, after all applicable fees have been paid by the User, to perform the maintenance services of the Treatment Systems and other components identified on the front of this document (hereinafter referred to as « Treatment Systems ») installed on the property of the User for a period of one (1) year or more as required by the regulation in effect. Please refer to the Maintenance section of the Owner's Manual for more details regarding what is included and excluded in the maintenance service of your Treatment System.
2. The maintenance of the Treatment System must be performed by Premier Tech, a representative of Premier Tech or a authorized third party.
3. The price of the annual maintenance Agreement must be paid to Premier Tech by the User and renewed annually by the User. These costs cover the services detailed in the Owner's Manual. This amount does not include the cost of purchase, installation, replacement or any repair required on a Treatment System not covered by the manufacturer as per the terms of the Warranty Certificate of the system inside the Owner's Manual.

For more information about the maintenance of your Treatment System, please consult the Owner's Manual or contact us at 1-800-632-6356. One of our Customer Service representatives will be happy to assist you. Premier Tech and the User acknowledge that this Agreement is related to the purchase of a Treatment System by the User and that it is only valid if such a purchase was made.

### OBLIGATIONS OF USER

4. The User agrees to provide a duly completed and signed copy of this Agreement to Premier Tech in order for the annual maintenance to be performed on the Treatment System and the warranty to be honored by Premier Tech. A valid maintenance Agreement being an essential condition to the validity of the warranty of the Treatment System (please refer to the Certificate of Warranty of the Owner's Manual).
5. When local regulations in effect require it, the User agrees to provide a duly complete and signed copy of this Agreement to the municipality where the Treatment System was installed (please validate if this is necessary with your municipality).
6. The User agrees to grant access to the installed Treatment System to Premier Tech, a representative of Premier Tech or a duly authorized third party in order for the maintenance to be properly completed. The lids of the Treatment System shall at all times remain accessible and free of any encumbrance. Additional fees will be charged to the User if the annual maintenance must be postponed to a later date if Premier Tech, a representative of Premier Tech or a authorized third party cannot access the Treatment System to perform the maintenance as planned.
7. Should the access of the User's premises not be practicable for vehicles, the User agrees to provide to Premier Tech, a representative of Premier Tech or a authorized third party with reasonable and practicable access so that the services detailed in this Agreement can be performed.
8. The User acknowledges receipt of a copy of the Treatment System Owner's Manual from Premier Tech or the installer of the Treatment System. The User acknowledges having read and understood this document and agrees to comply with the directions and guidelines contained in the Owner's Manual regarding the use of the Treatment System.
9. The User hereby agrees to keep the Owner's Manual, the Annual Maintenance Program and Warranty Activation Form, the Warranty Certificate and the Proofs of Maintenance provided annually by Premier Tech, a representative of Premier Tech or a authorized third party. The User also agrees to provide all these documents. To any subsequent purchaser of the premises so that the new User may benefit from the Premier Tech Maintenance Program, enjoy the protections offered by all Premier Tech warranties and be informed of the terms and conditions of the Warranty Certificate and of the obligations of the User of an onsite treatment system.

10. The User agrees to make no changes in the use or function of the building serviced by the purchased Treatment System, nor any modification to the system's installation as originally specified and approved by the municipality under applicable laws and regulations. Any change or modification shall only be made if pre-authorized jointly by the municipality and Premier Tech. Any change or modification without prior authorization from Premier Tech will void the warranty of the Treatment System.

### GOVERNING LAWS AND JURISDICTION

#### 11. For Canadian customers:

- 11.1. The present Agreement shall be interpreted and governed in accordance with the laws applicable in the Province of Quebec, Canada.
- 11.2. Parties agree to elect the courts of the district of Kamouraska (Province of Quebec, Canada) exclusively as the proper forum for the hearing of any claim or legal proceedings in connection with the present Agreement.

#### 12. For U.S. customers:

- 12.1. This Agreement shall be governed by the laws in effect in the State in which this Agreement has been entered into.
- 12.2. The Parties agree, in respect to any claim or legal proceedings for any purpose whatsoever in connection with this Agreement, to elect the county of Bucks County (Pennsylvania) as the proper forum for the hearing of any claim or legal proceedings to the exclusion of any other judicial district which may have jurisdiction to hear such dispute according to the requirements of the law.
- 12.3. For Arkansas, California, Florida, New Jersey, North Carolina, Ohio, Virginia and Washington, please validate the requirement of the local regulation in effect with your municipality to find out more about the responsibility of the homeowner regarding the maintenance of a wastewater treatment system for an isolated dwelling.

### ECOFLO COMPACT AND LINEAR MAINTENANCE PROGRAM (if applicable)

Depending on the territories, the purchase price of the Ecoflo compact biofilter may include one of the three following maintenance services:

1. The costs of a Courtesy Visit for which a local service partner will visit the property within 90 days of the activation of the Ecoflo compact biofilter to explain the functioning of the septic system, its annual maintenance program and perform a visual inspection to verify that:
    - a) the tipping bucket and distribution plates are properly in place
    - b) the electrical equipment (if applicable) has been hooked-up
    - c) guidelines regarding distances around the system and surcharges to avoid placing on the unit have been respected
  2. The cost of the first annual maintenance which will be performed by the local service partner during the year following the purchase of the system.
- or
3. As required by local regulations.

Contact the Premier Tech Customer Service at 1-800-632-6356 for more details or if you have any questions.

#### IMPORTANT

The system's Courtesy Visit consist of a visual inspection limited to the products manufactured or sold by Premier Tech and it excludes any validation of the proper installation or functioning of the treatment system.



### PT Water and Environment

1, avenue Premier +1 800 632-6356  
Campus Premier Tech F. 418 867-8883  
Rivière-du-Loup (Québec) info.ptwe.na@premiertech.com  
G5R 6C1 CANADA PT-WaterEnvironment.com